

The ABC's of DRO's

AN INTRODUCTION TO MEASURING SYSTEMS

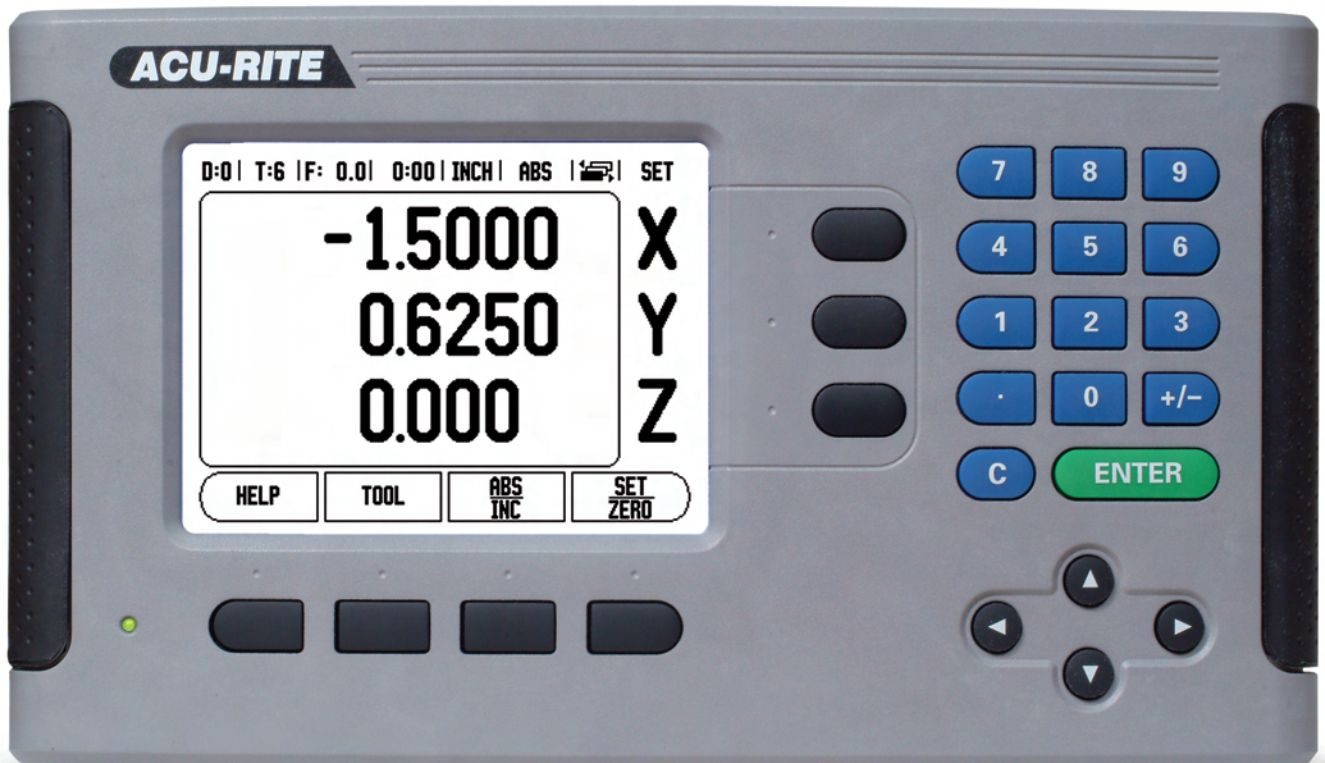

ANILAM ACU-RITE®

The ABC's of DROs

Authored by:
John Parker
Stephanie Bussman

Copyright © 2008 Acu-Rite Companies Incorporated. All rights reserved. No part of this book may be reproduced or utilized in any form or by any means, electronic or mechanical, including photocopying, recording or by any information storage and retrieval systems, without permission from Acu-Rite Companies Incorporated.

TABLE OF CONTENTS

Introduction	5
What is a DRO and How Does It Work?	6
Why They Are Used?	8
How and Where They Are Used?	9
FYI: How Machine Tool Errors Occur	12
The Economics of Readout Systems	14
Glossary	16
Test Your Knowledge	19
Application For Recognition of Completion	22



Acu-Rite Companies Inc. is a leading supplier of digital readout systems, precision glass scales and control systems throughout the world. Acu-Rite Companies Inc. has developed a distribution network that is second to none with corporate offices headquartered in Jamestown, NY along with sales and marketing offices in Los Angeles, CA, France, Germany, Great Britain, Italy, China and Taiwan.

THE ACU-RITE COMMITMENT

At Acu-Rite Companies Inc. we are committed to deliver products and services that exceed our customer's expectations. To do this, each of us must do our jobs right the first time, every time. Together we will continuously improve ourselves, our processes and our products to serve our customers.

CONTACTS

Acu-Rite Companies Inc. Territory Manager

ACU-RITE COMPANIES INC.

One Precision Way,
Mason Industrial Park,
Jamestown, NY 14701

Phone: 1-800-344-2311

Fax: 716-661-1888

On the web: www.acu-rite.com or www.anilam.com

INTRODUCTION

Acu-Rite Companies Inc. readouts are application-specific systems for the manual machine tool industry. The primary benefit is saving time and increased productivity. The addition of a readout system on any machine allows for reduced scrap due to the elimination of measuring inaccuracies. Machine operators are relieved of tedious setup, positioning and checking operations so more time is spent machining. Training is easier and faster, elevating less-experienced operators to obtain optimum production levels in a shorter time. The return on investment (ROI) on savings averages less than 30 days.

DIGITAL READOUTS

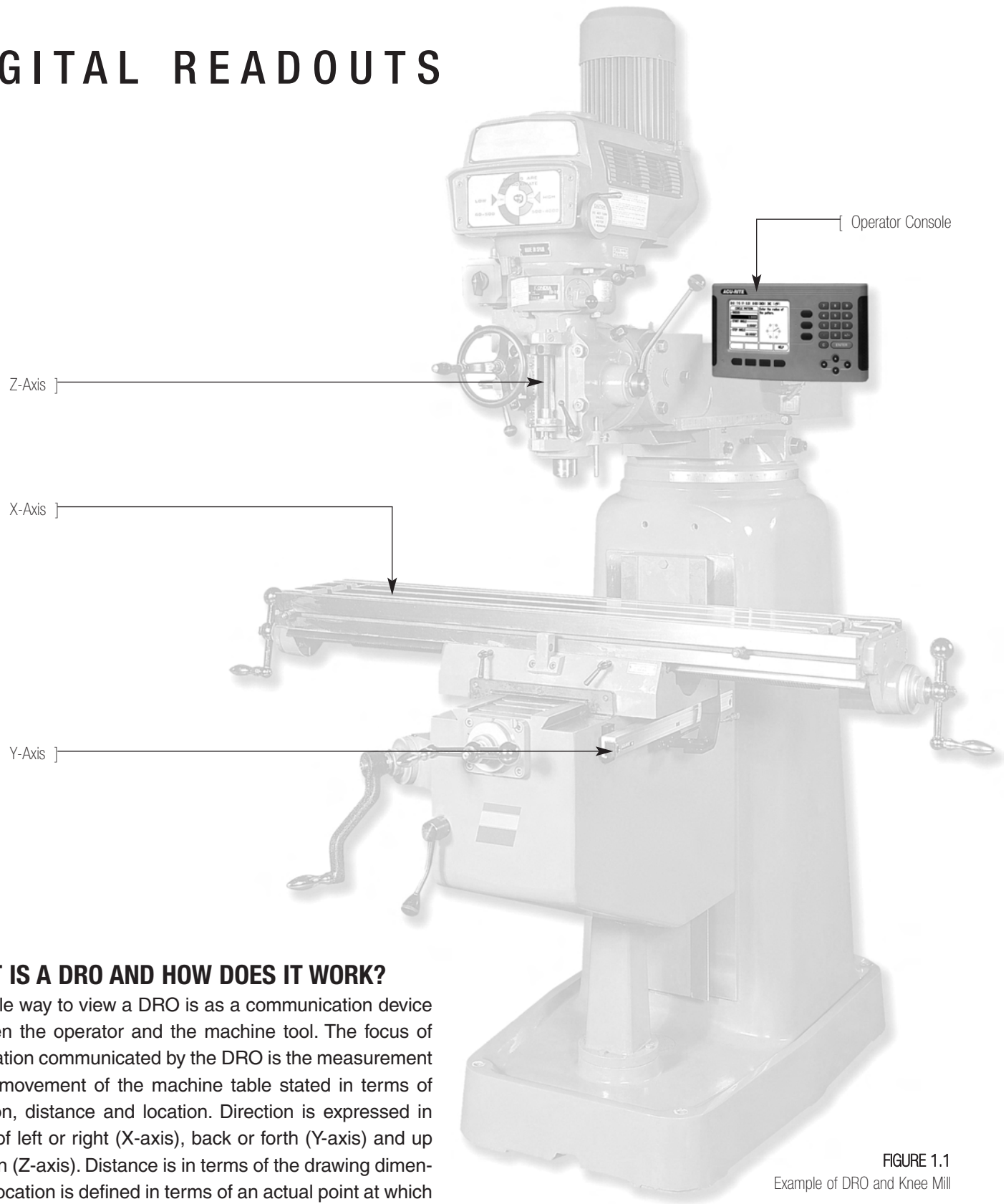

FIGURE 1.1

Example of DRO and Knee Mill

WHAT IS A DRO AND HOW DOES IT WORK?

A simple way to view a DRO is as a communication device between the operator and the machine tool. The focus of information communicated by the DRO is the measurement of the movement of the machine table stated in terms of direction, distance and location. Direction is expressed in terms of left or right (X-axis), back or forth (Y-axis) and up or down (Z-axis). Distance is in terms of the drawing dimension. Location is defined in terms of an actual point at which measuring takes place. The DROs function is to display the changes in these positions as a workpiece is moved.

DIGITAL READOUT (DRO) - a DRO is a digital display console that is used as an interface between the machine operator and tool/workpiece position. Acu-Rite Companies Inc.'s readout systems are designed for three (3) application areas: milling, turning, grinding/general purpose.

THE FOLLOWING ARE BASIC FEATURES FOUND ON AN ACU-RITE COMPANIES INC. DRO:

- 1, 2 or 3 axes 5.7" transmissive LCD display
- Die-cast metal enclosure.
- Sealed, 3D tactile feel color keypad
- Absolute/Incremental Display
- Preset and Zero reset capability
- Near-zero warning
- Inch to Millimeter display
- Linear error compensation for machine tool inaccuracies
- Tool offsets
- Bolt hole patterns
- Position-trac™
- 200mm reference mark intervals.



FIGURE 2.1 – 2.4
(Clockwise from top left.) VUE, 200S, Wizard 411, Wizard 550

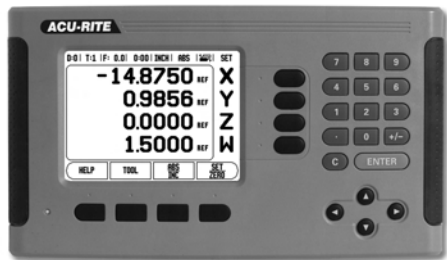

THE 300S AND WIZARD 1000 ARE DISTINGUISHED FROM THE OTHER DRO BY THESE FEATURES:

- 2, 3 or 4 axes 5.7" transmissive LCD display
- Programming capabilities with program management
- Multiple display mode. DRO1 and DRO2
- Skew Compensation



FIGURE 2.5 – 2.6
300S, Wizard 1000

WHY THEY ARE USED



FIGURE 3.1 – 3.3
200S

With the greater positioning accuracy of the system, the inherent accuracy of the machine tool is used to full advantage. Therefore, the likelihood of producing scrap parts is greatly reduced. The time the operator used to spend setting the coordinates for positioning is now spent machining more parts. This translates into greater operator efficiency and in turn, increased productivity. The results are savings in operating expenses and therefore a more profitable shop.

Aside from the elimination of positioning problems, there are other operator-oriented benefits. For example, there is no longer a need to do paper-and-pencil calculations for offsets or other dimensions that may not appear on the drawing since exact positioning is displayed on the DRO.

Another is the reduction in operator fatigue associated with

counting hand wheel turns and straining to read verniers, a factor that frequently affects operator performance and satisfaction.

Lastly, a digital measuring system makes training of new or less-experienced operators much easier and less time consuming.

The following machine tools represent typical applications for Acu-Rite's readout systems:

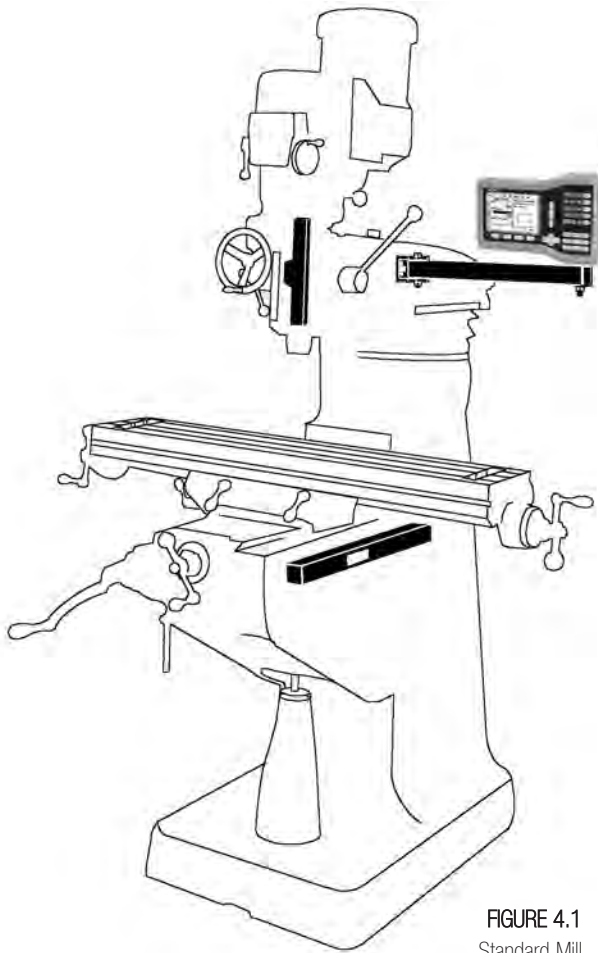

FIGURE 4.1
Standard Mill

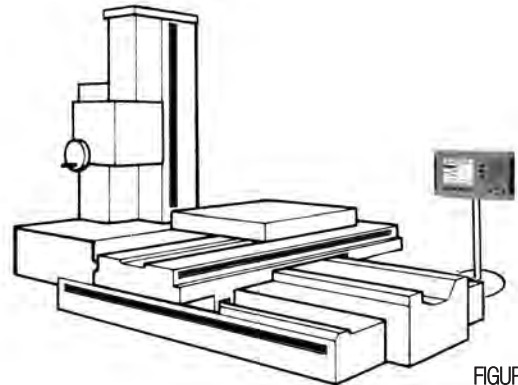

FIGURE 4.1
Boring Mill

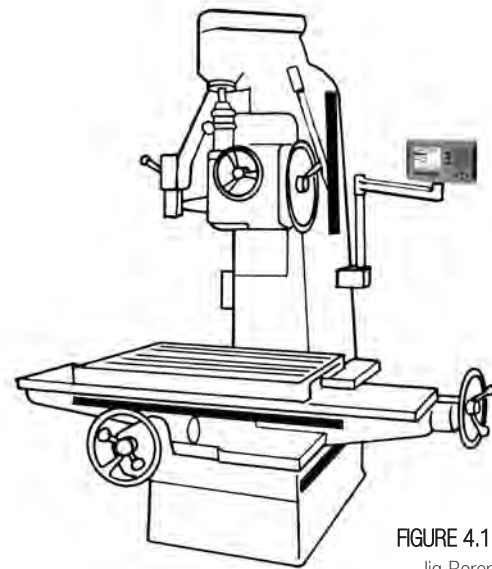

FIGURE 4.1
Jig Borer

MILLING

Mills, vertical boring mills and universal horizontal/vertical mills. Most system retrofits will require either a VUE, Wizard 411, 200S, Wizard 550, 300S, Wizard 1000 or a MILLPWR with a minimum of two encoders.

HOW AND WHERE THEY ARE USED

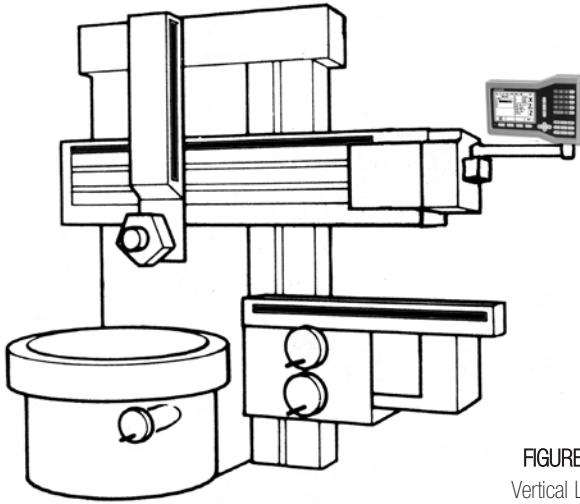

FIGURE 5.1
Vertical Lathe

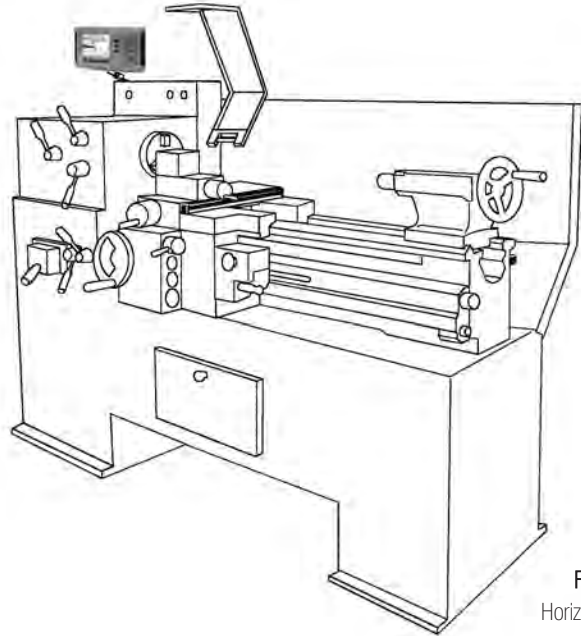

FIGURE 5.2
Horizontal Lathe

TURNING

Retrofitted to almost any lathe or vertical turning lathe. Most system retrofits will require either a VUE, Wizard 411, 200S, Wizard 550, 300S or Wizard 1000 for turning with a minimum of two scales (don't forget that the 300S and Wizard 1000 can accommodate up to four (4) machine tool axes). Scale resolution is normally $5\mu\text{m}$ for the Z or longitudinal axis and $1\mu\text{m}$ for the X or cross slide axis.

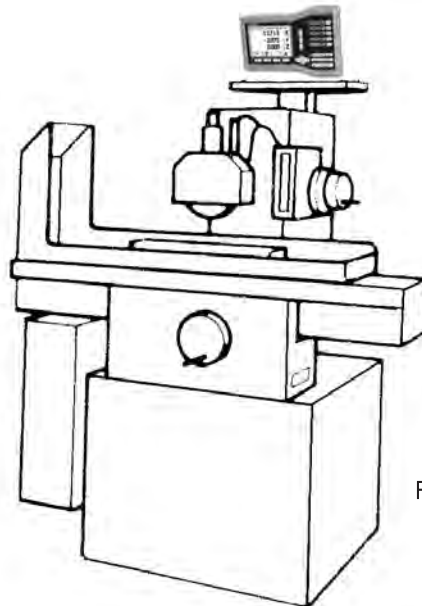

FIGURE 5.3
Grinder

GRINDING

Retrofitted to almost any surface grinder. Most system retrofits will require either a VUE, Wizard 411, 200S, Wizard 550 with a minimum of one scale. Scale resolution is usually $1\mu\text{m}$.



FIGURE #.4
Optical Comparator

OPTICAL COMPARATOR

Restores the linear accuracy of comparator; eliminates dependence on accuracy of ball screw drives with inherent backlash. Acu-Rite's Digital Readouts enhance coordinate measuring immensely and effect great savings in both time and accuracy. They require either a VUE, Wizard 411 general purpose or 200S, Wizard 550 general purpose with a minimum of two encoders ($1\mu\text{m}$ for 2 axes).

FYI: HOW MACHINE TOOL ERRORS OCCUR

It is common knowledge that all machine tools - new and old - contain some error in the accuracy of moving components when compared to a standard that is known to be true. This area of concern is important enough for you to learn more about these errors and why they occur.

In every machining operation, there is always some degree of error or inaccuracy due to at least one of the following machine tool deficiencies:

- a.) Gravity causes deflections in the machine tool structure, particularly when a heavy workpiece is placed on a machine with overhanging table or ways. A result of these deflections is called Abbe error. (The following paragraphs provide further explanation.)
- b.) The fit between mating surfaces is loose, because of manufacturing tolerances, subsequent wear or improper gib adjustment.
- c.) The ways are not scraped straight or are not aligned perfectly at assembly.
- d.) Driving and cutting forces cause deflections, since no material is totally rigid.
- e.) Temperature variations can distort machine geometry.

In addition, machine tables and ways can be forced out of alignment if you use the locks improperly. Tables that are not completely locked in position will shift from the forces of machining and eventually wear.

Abbe error (also called machine geometry or transfer error) is progressive fault occurring mainly in machine tool tables or beds. It occurs in other moving parts also, but we'll limit our discussion here to mill tables. Gibs and table

ways can wear due to an increase in pressure at the edge of the machine way, on both the knee and center of the table. This causes increased wear at these points as the center of gravity of the table moves with an increasing overhang.

The shift of weight is gradual as the table moves from the center; therefore the wear is also gradual. The result is the formation of an arc shape along the table and knee, concave to the ways. Pressure of the gib against the way causes the gib to wear. Often when a short travel is used, retightening the gib causes localized wear of the way.

The scale attached to the table measures its horizontal motion with respect to the fixed reading head. A worn table, however, follows the curvature of the arc, resulting in an error in the movement of the workpiece relative to the cutter. In the case of the milling machine, the workpiece is moving too far.

Acu-Rite Companies Inc. readout systems include automatic linear error calculation and stored error compensation factors in all systems as a standard feature. Both linear and non-linear error compensation can be entered into the readout. Error compensation corrections of up to ± 99999 ppm (parts per million) can be entered.

PRECISION GLASS SCALES

Acu-Rite Companies Inc. manufactures application-specific readout systems for the manual machine tool industry. Each system includes a VUE, Wizard 411, 200S, Wizard 550, 300S or Wizard 1000 readout, a minimum of one precision glass scale and associated hardware used in the mounting of the readout and precision glass scale(s).



FIGURE 1.1
Acu-Rite Precision Glass Scales
(from top to bottom) ENC 250,
SENC 150, ENC 125 T, SENC 50

Scales are mounted to the motion axes and provide positional feedback to the readout to inform the operator of tool/workpiece position. The scale is composed of two (2) integral components; the precision glass scale and the electronic reader head.

Acu-Rite Companies Inc.'s Premium precision glass scales consist of chromium lines on a glass substrate with up to 1,270 lines per inch with distance encrypted reference mark placed every 50mm. Glass scales are manufactured in a Class 100 Clean Room that is one of a kind in the United States. The reference mark is used to recover tool/workpiece position upon power up or after an accidental loss of power or ending work for the day. This capability is called Position-Trac™ and is available on the SENC 150 Scale, ENC 250 Scale and the SENC 50 Scale.

The ENC 125 is also available in 5µm resolutions. It is only compatible with the VUE and Wizard 411 readouts.

Precision glass scales are used because of their high accuracy and stability. Glass resists change in size, shape and density regardless of variations in temperature. This quality provides glass scales with exceptional accuracy for travel lengths from 1" - 120" (longer travel lengths available) in resolutions from 5µm (0.0005") to 0.5µm (0.00002"). Acu-Rite Companies Inc.'s scales are easy to install and eliminate errors associated with machine wear and backlash.

THE ECONOMICS OF READOUTS

When it comes to seeing the actual benefits of adding a readout to a manual machine tool often the most convincing argument is the rise in productivity due to increased utilization, output and accuracy. Jobs that might have been vended out due to a lack of time and capability can be kept in-house with a readout system. Similarly, jobs that were turned down or quoted too high in the past can be handled due to the increased capability of the shop.

Profit centers are what some shop managers call machines retrofitted with readouts. Others say their DROs “paid for themselves in just 90 days in reduced scrap alone. Everything saved now is pure additional profit!”

It is easy to spout praises once a readout system is working for you, but how do you help the potential buyer justify the need to make that first purchase? There are at least two methods you can use to figure out the potential gains. One is the annual dollar savings method; the other is the purchase payback method. Both can be represented by mathematical formulas.

CALCULATING ANNUAL SAVINGS

$$S = \frac{HNC}{60} (Td - Tr)$$

S = the annual savings

H = the number of working hours per year

N = the average number of moves per hour

C = the cost per hour of operator

Td = the indexing time in minutes using dials or rods.

Tr = the indexing time with digital readout

Lets assume that your machine operator works 2000 hours a year (H) and makes an average of six moves each hour (N). You pay the operator an hourly wage of \$10.00 (C). He “eyeballs” his moves at an average of 2.75 minutes per move (Td), or uses a DRO, averaging 1 minute each move (Tr).

WHEN THESE VALUES ARE INSERTED INTO THE FORMULA, THE RESULT IS PERSUASIVE:

$$S = \frac{2000 \times 6 \times 10}{60} (2.75 - 1.00)$$

$$S = \$3,500 \text{ (per DRO/operator)}$$

As you can see, the reduced time (or increased speed) for the job with a DRO-equipped machine is enough by itself to warrant the purchase (averaging \$1500). A shop working two or three shifts will increase its relative number of moves proportionately, and yield savings significantly above our \$3,500 example.

... others say their DROs
“paid for themselves in just 90 days
in reduced scrap alone.
Everything saved now is pure
additional profit.!”

When you install a digital measuring system on most machine tools, you can expect an annual return of at least 500% on your investment. The exact return in both dollars and time depends, of course on the type of machine and its usage. Below is a basic formula which you can use for justification or a purchase.

CALCULATING PAYBACK

$$\text{PAYBACK TIME} = \frac{I}{ABC}$$

- I = Dollars Invested
- A = Machine revenue in \$/hr
- B = Hours per day worked
- C = Productivity increase in %

Putting this formula to work is simple. We'll use an investment figure (I) of \$1600, the cost of installing an average system on a small mill. Using a machine revenue rate of \$20 per hour (A) for and 8-hour day (B) we can assume a typically conservative increase of 25% in productivity (C).

WHEN THESE FIGURES ARE PLUGGED INTO THE FORMULA, THE RESULT IS:

PBT = PAYBACK TIME

$$\text{PBT} = \frac{1600}{20 \times 8 \times .25} = \frac{1600}{40}$$

PBT = 40 DAYS TO PAY FOR SYSTEM

If your shop operates 52 weeks a year, the annual return will be 6.5 times your investment (5.5 times after payback) or \$8,800 the first year.

Moreover, a machine utilization of three shifts per day will produce a proportionately greater return. Well worth the investment.

GLOSSARY

ABBE ERROR: 1) The easiest explanation for DRO purposes is: A measurement error due to the non-parallel motion of a machine slide compared with the measuring standard (scale). 2) A more technical definition is: A traverse error in a machine table (or other moving components) caused by insufficiently straight motion of machine slides. Machine geometry can be and (usually is) affected by gravitational deflection, particularly on an overhanging table or when workpieces are too heavy or too large for the table.

ABSOLUTE MEASUREMENT: The measurement of total distance moved along an axis from a fixed datum point (called absolute zero or zero reference) on, or fixed with reference to the workpiece.

ACCURACY: The degree to which it is possible to make linear measurements correctly with respect to a known standard that is true. For example, if you have a standard that is exactly 4.0000" in length and you make a measurement of the standard using the readout system, the readout should display 4.0000". If the length of the standard and the measured lengths are identical the readout system is deemed accurate. If there is any significant deviation, plus or minus, of the readout system display (e.g. 3.9993) an accuracy error in either the standard or readout system has been detected.

APPLICATION: A machine or machining situation where a readout system can be easily integrated to accommodate the travel, resolution and accuracy required.

AXIS (AXES): The axes are the machine's main lines of motion, around which the parts of the system are aligned. Scales are normally attached to the X (left to right axis), Y (front to back axis), and Z (up and down axis).

BACKLASH: This is the jarring reaction of loose or worn parts; also refers to the play in these parts due to their looseness.

CONVERSION: Metric to English

25.4mm = 1 inch

1mm = .03973"

0.01mm (10µm) = .00039"

5µm = .0002"

2µm = .0001"

1µm = .00005"

0.5µm = .00002"

Note: 1 micron is equal to .001mm

COORDINATE (SYSTEM): A system of axes. (See "Axis")

COUNTER: Alternate name for DRO, normally used to imply that the instrument adds or subtracts incremental measurements of motion; therefore, "counts."

CUTTER OFFSET: Refers to the radius or diameter of a cutting tool (drill, mill, reamer, etc.) that is added to or subtracted from the dimension used to machine the workpiece.

DATUM (POINT): Usually applied to any reference point from which measurements are taken for machining motions and operations. Also, known as machine zero and/or workpiece zero.

DIGITAL READOUT (DRO): The readout portion of the DRO System. Composed of a LCD and a sealed 3D tactile-feel color keypad. (The words Console and Counter are also used as alternate names for DROs.)

DIMENSION: A specific measure of distance between two points or planes (based on linear movement along a given axis.)

GLASS SCALE: A precisely ruled length of glass substrate, on which a uniformly spaced pattern of chrome lines is deposited, which allows light to pass through intermittently for the purpose of measurement. The patterned glass functions in combination with an index grating (to form a fringe pattern) and a photoelectric sensor to generate signals to the DRO.

GLOSSARY

*** SCALE (LINEAR):** A scale is composed to the precision glass scale (1" to 120" in length, longer lengths are available in multi-sections) and a reader head. The reader head contains the electronics to sense the movement of the glass scale and converts this motion into a digital signal that is detected by the readout and displayed as the distance moved.

*** SCALE (ROTARY):** Functionally the same as a scale except that it uses an optical disk rather than a scale and it usually mounts directly to the lead screw instead of the table. (Also, measured in radius/diameter and degrees.)

Note: This mounting configuration will not compensate for lead screw backlash or machine wear.

INCH-TO-METRIC CONVERSION: A switch feature on many DROs that permits instant conversion of measurement and display from inches to millimeters and vice versa.

INCREMENTAL MEASUREMENT: A measurement between two successive points on a workpiece, usually with a DRO system, incremental (point-to-point) positioning is done from a displayed preset dimension to zero, or from zero to the dimension, then the display is reset to zero.

LCD (LIQUID CRYSTAL DISPLAY): A digital display that uses liquid crystal cells that change reflectivity in an applied electric field. This exclusive technology allows Acu-Rite Companies Inc.'s readouts to showcase full part graphics as well as the traditional readout screen.

LINEAR MEASUREMENT: A straight-line distance traversed and measured by a transducer attached to the machine in the axis of movement.

METROLOGY: Metrology is the science and technology of precision measurements.

MICRON (μm): 1 micron is equal to .001mm or .00005".

MICROPROCESSOR: The solid-state electronic "heart" of a programmable DRO, it interacts with the program and storage memories and the input/output electronics of a DRO's computer.

MULTIPLE DISPLAY VIEWS: 300S has 2 DRO display modes that can be setup allowing the operator to customize the axis displayed on the readout.

OFFSET: Refers to the radius or diameter of a round cutting tool by which a dimension is modified in order not to over cut or under cut the required dimension.

POINT: A location on a workpiece drawing corresponding to either a termination or a dimension or the center point of a hole. Except for the zero reference (start) point, all other points involve a machining operation and are called either reference points (tool moves from) or target points (tool moves to).

POSITION-TRAC™: A feature of the readout system that allows rapid recovery of position once power has been restored to the system after shutdown or accidental loss of power.

POWER RECOVERY: A lighted message on a DRO display signifying a power interruption or a previous "power-off" condition.

PRECISION: The closeness or (tolerance) of agreement among repeated measurements of the same characteristic, by the same method, under the same condition.

PRESET: Most digital readouts have this feature, which permits presetting (entering) the machining dimension and machining to zero. It also permits presetting a tool offset that is automatically calculated into the dimension.

GLOSSARY

PROGRAM: A sequence of instructions entered into the memory of a programmable readout and retrieved in a pre-determined fashion to be used for machining operations or auxiliary functions. Also the layout and entry of these instructions.

QUADRATURE: A sine or square-wave signal whose phase differs by 90° with respect to a base signal. The quadrature signal is necessary for bi-directional counting.

READER HEAD: A photo-electric device that is used to convert the line pattern on the glass scale to a digital signal that is the input to the readout to display tool/workpiece position.

REFERENCE MARK: This is a pattern on the glass scale that is sensed by the reader head and is used for the Position-Trac™ feature or to quickly reset the readout system to zero.

REPEATABILITY: This is the capability of the scale to return to an identified position within the specified tolerance. A repeatable scale is one that begins at zero on both an indicator and readout system. The table or tool is moved away from zero on both the indicator and readout system. When the table or tool is returned, both the indicator and readout system should again read zero. If this operation can be performed numerous times within a specified tolerance, the readout system and machine are judged to be repeatable.

RESOLUTION: This is the smallest unit of motion that a readout system is capable of measuring and displaying. Acu-Rite readout systems are accurate up to 0.00002" or 0.5 micron.

SCALE ASSEMBLY: Consists of a glass scale enclosed in aluminum housing with sealed, die-cast metal end caps. To enhance glass scale durability, it is further protected from

the environment by a recessed highly chemical-resistant, interlocking lip seal.

SYSTEM: A digital measuring system includes the DRO and one scale for each measured axis of movement, plus electrical connections and any necessary mounting bracketry.

TRAVEL: Term used to describe the movement of the machine tool or table.

WORKPIECE: The material or part from which the finished part is machined. (Also, the finished part.)

X-AXIS: Usually the plane of movement on a machine table whose direction is either left (+) or right (-) and horizontal to the floor.

Y-AXIS: Usually the plane of movement on a machine table whose direction is either back (+) or forth (-) and horizontal to the floor.

Z-AXIS: Usually the plane of movement on a machine table whose direction is either up (+) or down (-) and perpendicular to the floor.

Note: On a lathe the x-axis is the diameter (cross slide) and the z-axis is the longitudinal. When lathe parts are inspected they are set up vertically and therefore, the length becomes the height and the diameter is checked horizontally.

ZERO REFERENCE: The point selected on or near the workpiece from which positioning is started or, in some cases, referenced for the entire machining operation. (Also see Datum and Absolute Measurement.)

ZERO RESET: Automatic or manual zeroing of the measurement (or count) displayed on the DRO. (Another term for Reset.)

TEST YOUR KNOWLEDGE

This test will evaluate your basic knowledge of Acu-Rite Companies Inc. Readout Systems and more importantly help you begin to identify where Acu-Rite Readout Systems can be used. Upon completion of this test please attach it, along with the completed application, and return it to receive a complimentary gift from Acu-Rite Companies Inc.

Circle the most “accurate” answer.

1. A readout system includes which of the following?

- (a.) Machine tool and workpiece
- (b.) Computer
- (c.) Readout, scale and mounting hardware
- (d.) All of the above

2. Acu-Rite Companies Inc. systems can be retrofitted to what type of metalworking machines?

- (a.) Grinding
- (b.) EDMs
- (c.) Milling
- (d.) Turning
- (e.) All of the above

3. Resolution is defined as?

- (a.) The degree to which it is possible to make linear measurements correctly with respect to a known standard.
- (b.) The smallest unit of motion that a readout system is capable of measuring and displaying.
- (c.) Movement of the machine table or tool
- (d.) All of the above

4. Acu-Rite Companies Inc. Precision Glass Scales are available in what resolution(s)?

- (a.) 5 μ m (0.0002")
- (b.) 1" to 120"
- (c.) 1 μ m (0.00005") and 0.5 μ m (0.00002")
- (d.) A and C above
- (e.) None of the above

5. X-axis travel in a milling application is defined as?

- (a.) The plane of movement on a machine table whose directions are either back or forward and horizontal to the floor.
- (b.) The plane of movement on a machine table whose directions are either left or right and horizontal to the floor.
- (c.) The plane of movement on a machine table whose directions are either up or down and perpendicular to the floor.

6. The Position-Trac feature of Acu-Rite Companies Inc. SENC 150 & SENC 50 Precision Glass Scale is?

- (a.) A pattern on the scale glass that is read by the reader head to reset the readout to zero.
- (b.) A term used to describe the movement of the machine table or tool.
- (c.) A feature of the readout system that allows rapid recovery of position after a power loss.

7. Why would you retrofit a machine tool with Acu-Rite Companies Inc. Readout Systems?

- (a.) Reduce operating expenses
- (b.) Increase profits
- (c.) Reduce or eliminate scrap
- (d.) Increase operator performance and reduce fatigue
- (e.) All of the above

8. A Reader Head is defined as?

- (a.) A scale mounted to the motion axes.
- (b.) Chromium lines on a glass substrate and manufactured in a Class 100 Clean Room.
- (c.) A photoelectric device that is used to convert the line pattern on the glass scale to a digital signal.
- (d.) All of the above.

9. Accuracy is defined as?

- (a.) The degree to which it is possible to make linear measurements correctly with respect to a known standard.
- (b.) The smallest unit of motion that a readout system is capable of measuring and displaying.
- (c.) Movement of the machine table or tool.

10. What benefit(s) do Precision Glass Scale(s) provide?

- (a.) High accuracy and stability
- (b.) Easy to install.
- (c.) Eliminates backlash or wear of the machine tool.

11. The 300S Readout has which additional features?

- (a.) Multiple display views
- (b.) 1 to 4 axes of motion can be displayed.
- (c.) Programming capabilities
- (d.) Built-in assistance, reference tables & calculators.
- (e.) all of the above

12. The Acu-Rite Companies Inc. 200S and Wizard 550 are the latest in digital readout technology because?

- (a.) They have a crystal clear 320 x 240 LCD display that replaces the traditional LED and VFD used by others.
- (b.) All prompts, instructions and help functions are accessible on screen and its no longer necessary to constantly refer to a manual.
- (c.) The user can configure the console to 2- or 3-axes display and can set application to milling, turning or general purpose accordingly.
- (d.) All of the above.

13. The Acu-Rite Companies Inc. VUE and Wizard 411 readouts have placed reference marks at what intervals?

- (a.) 100mm
- (b.) 200mm
- (c.) 300mm
- (d.) 400mm

Call Acu-Rite Companies Inc. at 1-800-344-2311 and record the name and telephone number of your Acu-Rite Companies Inc. territory manager.

Name _____ Phone Number _____

APPLICATION FOR RECOGNITION OF COMPLETION

Name _____

Company _____

Address _____

City _____ State _____ Zip Code _____

Phone _____ Fax _____

E-mail _____

Mailing Address

Name _____

Address _____

City _____ State _____ Zip Code _____

Signature _____ Date _____

Acu-Rite Companies Inc.

One Precision Way, Jamestown, NY 14701
Tel: (800) 344-2311 or Fax: (716) 661-1888
www.acu-rite.com • www.anilam.com
Attention: Jennifer Stafford

ANILAM ACU-RITE®